

Manhole access sizes and locations can be customised to suit client requirements (refer to notes below)

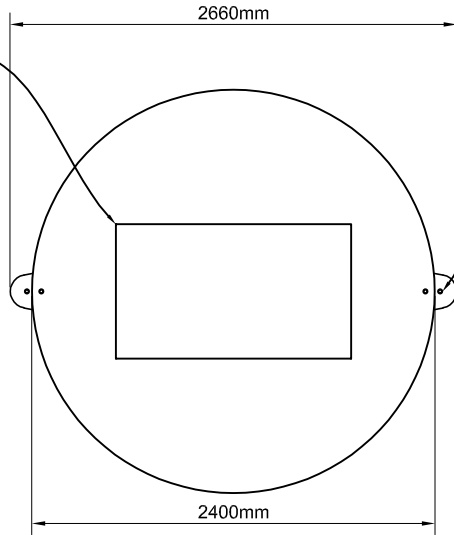

2 no. lifting points per section

LID PLAN

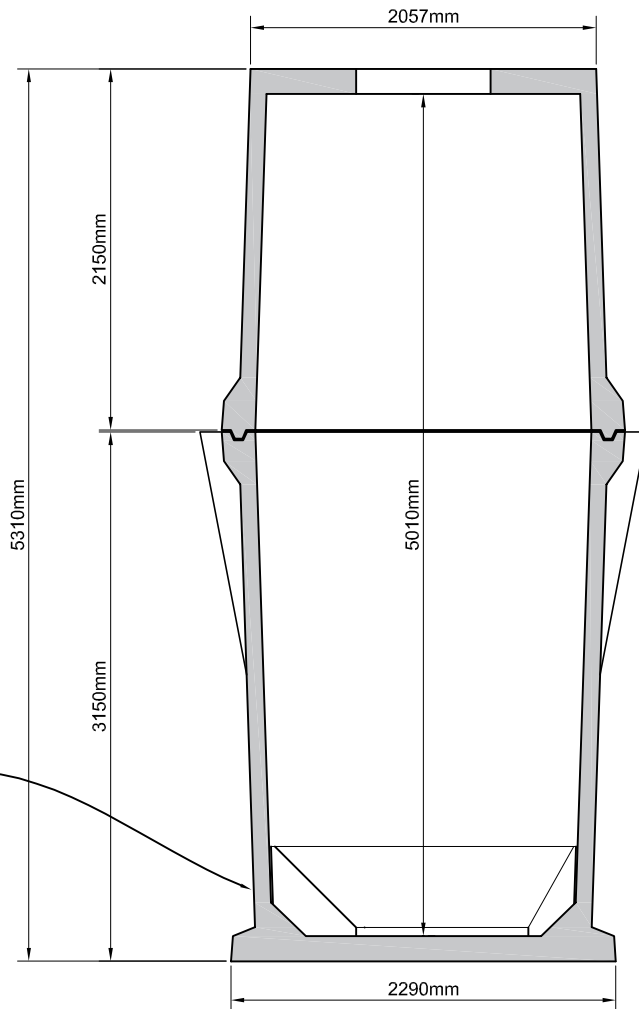

Optional precast benching available for pump sumps

TANK PLAN

Available Cores	Core size	Max invert from base
	63mm	5,050mm
	110mm (4")	5,000mm
	160mm (6")	4,950mm
	250mm (9")	4,860mm
	315mm (12")	4,795mm

Available Manhole openings	
A	- 1,200 by 750mm
B	- 1,400 by 800mm

**MOLLOY**  
ENVIRONMENTAL SYSTEMS  
Clara Rd., Tullamore, Co. Offaly  
T: 057 9326000 E: Info@mollyprecast.com  
F: 057 9326060 W: www.mollyprecast.com

NSAI Certified | ISO 9001:2015 | ISO 14001:2015 | ISO 45001:2018  
CIRI | ENGINEERS IRELAND | CPD TRAINING PROVIDER 2018

Tank lifting limitations:  
Max chain angle < 60°

Damage caused by incorrect lifting is the responsibility of others

**Notes:**

- Observe all safety regulations in regard to excavation and lifting requirements. Never leave opening uncovered or unattended at any time
- Specify any specific requirements prior to ordering. All civil works by customer
- Do not scale from this drawing. Only for illustration purposes

Title: P5 - 5m hgh pump sump  
 Drg. no.: PT-P5-01-081119  
 Capacity: 14,170 litres  
 Weight: Upper section - kg  
 Lower section - kg  
 Date: 08/11/2019  
 Drawn by: SF Checked by: